



WCBR190PF - WCBR190PA

Accessories / Accessori / Accessoires / Zubehör / Accesorios



L&L Luce&Light reserves the right to change the information contained in this document at any time without prior notice being given.
Le informazioni contenute nel presente documento possono essere modificate in qualsiasi momento senza preavviso e non comportano l'assunzione, nemmeno implicita, di alcuna obbligazione da parte della L&L Luce&Light srl.
 Les informations contenues dans le présent document peuvent être modifiées à tout moment sans préavis et ne comportent la prise en charge, explicite ou implicite, d'aucune obligation de la part de la société L&L Luce&Light srl.
Die in diesem Dokument enthaltenen Angaben und Daten können ohne vorherige Ankündigung geändert werden und stellen, weder implizit noch explizit, eine Verpflichtung seitens L&L Luce&Light srl dar.
 La información contenida en este documento puede ser modificada en cualquier momento sin previo aviso y no implica la asunción, ni siquiera implícita, de ninguna obligación por parte de L&L Luce&Light srl.

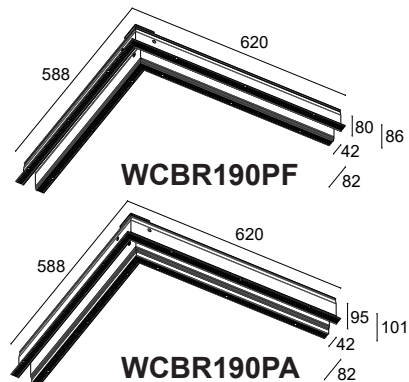

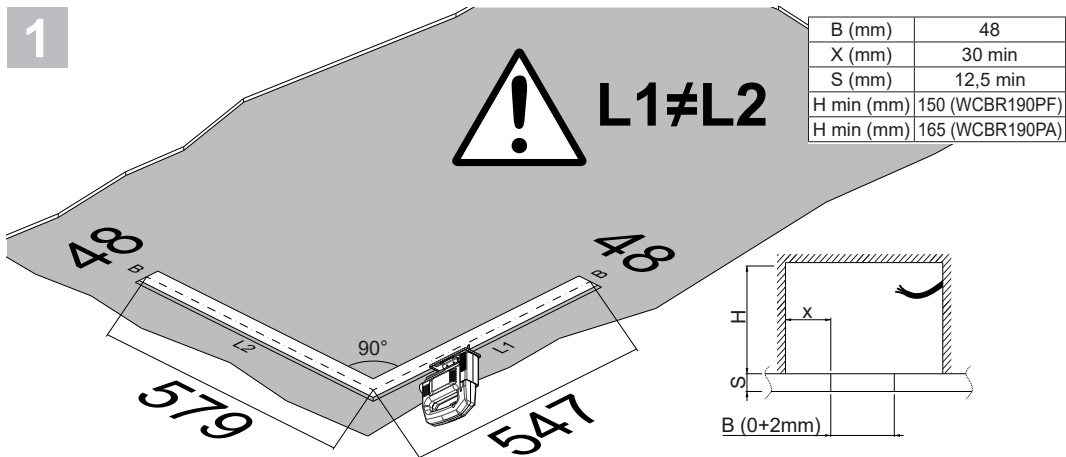

Le lunghezze di taglio L1 e L2 vanno calcolate sommando la lunghezza dei vari spezzoni ed aggiungendo 3 mm al totale.

The cutting lengths L1 and L2 have to be calculated by adding 3 mm to the single unit length.

Les longueurs de coupe L1 et L2 doivent être calculées en ajoutant 3 mm à la longueur unitaire.

Die Schnittlängen L1 und L2 müssen durch Addieren von 3 mm zur Einheitslänge berechnet werden.

Las longitudes de corte L1 y L2 tienen que ser calculado adicionando 3 mm a la longitud de cada unidad.

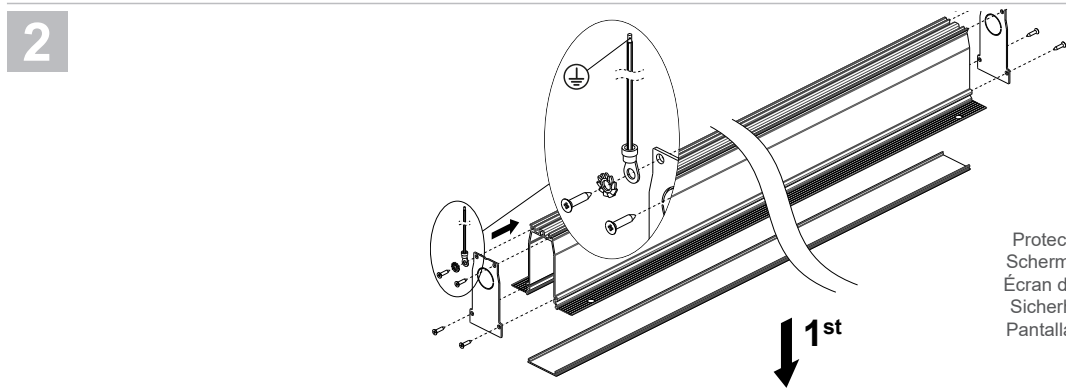

Protective screen
 Schermo protettivo
 Écran de protection
 Sicherheitsblende
 Pantalla protectora

**WABR100F
 or
 WABR100A**

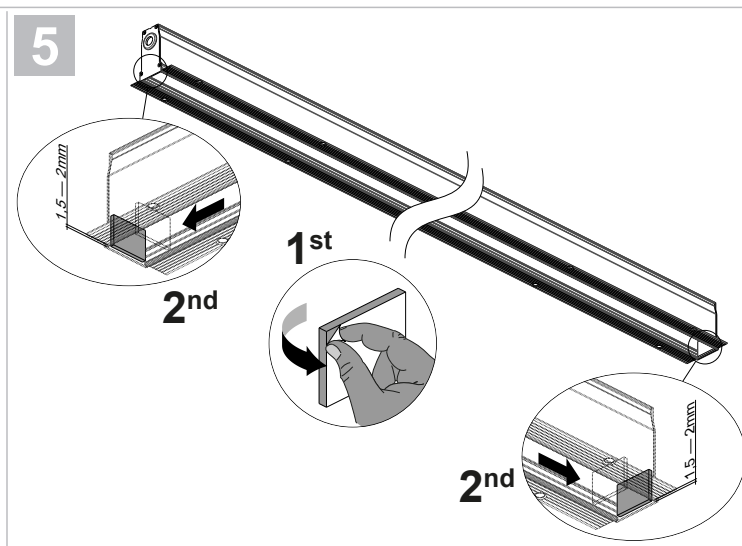
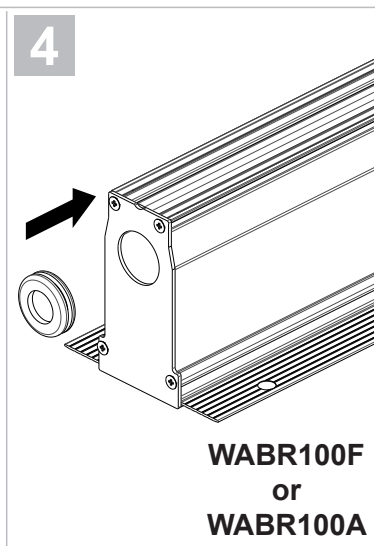
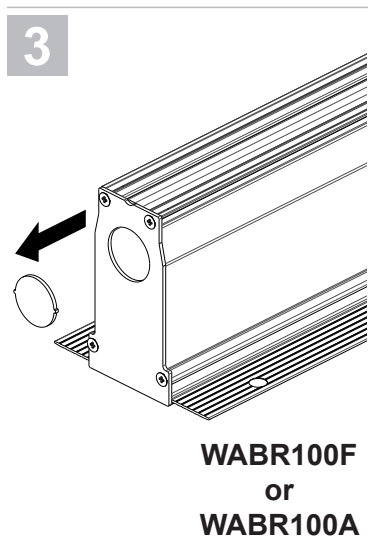

5 ON-OFF version

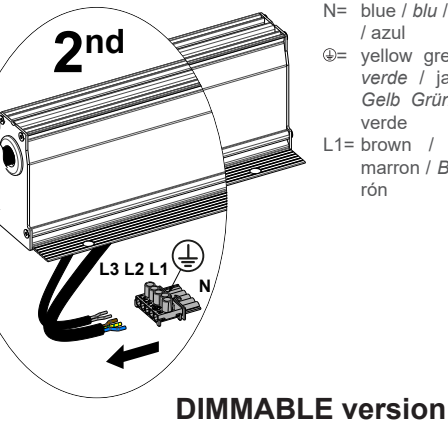
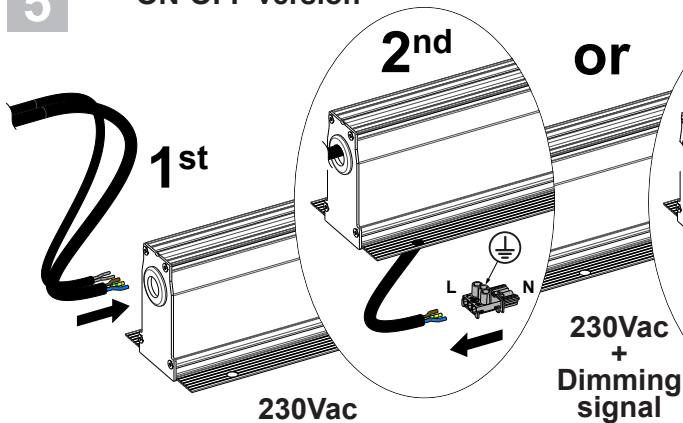

ON-OFF VERSION

N= blue / blu / bleu / Blau / azul
 ⊕= yellow green / giallo verde / jaune vert / Gelb Grün / amarillo verde
 L1= brown / marrone / marron / Braun / marrón

DIMMABLE VERSION

N= blue / blu / bleu / Blau / azul
 ⊕= yellow green / giallo verde / jaune vert / Gelb Grün / amarillo verde
 L1= brown / marrone / marron / Braun / marrón
 L2= dimming signal 1 / segnale dimmerazione 1 / signal de gradation 1 / Dimmsignal 1 / señal de atenuación 1
 L3= dimming signal 2 / segnale dimmerazione 2 / signal de gradation 2 / Dimmsignal 2 / señal de atenuación 2

7

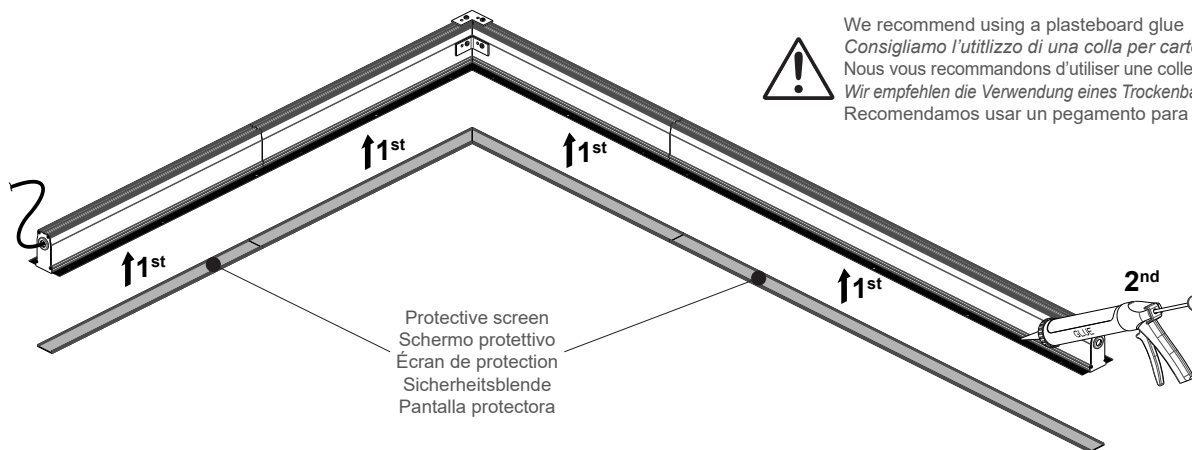

8

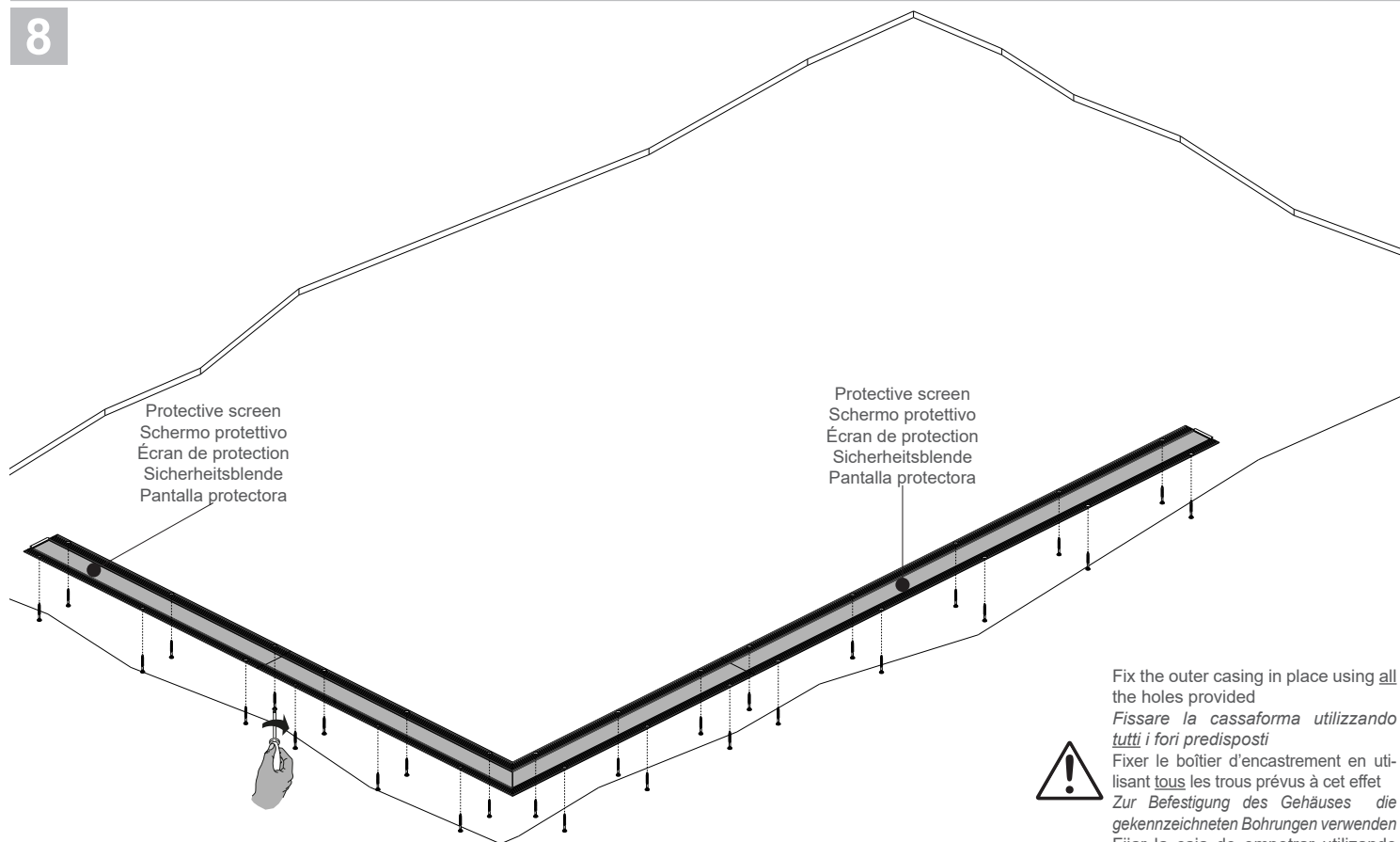

8

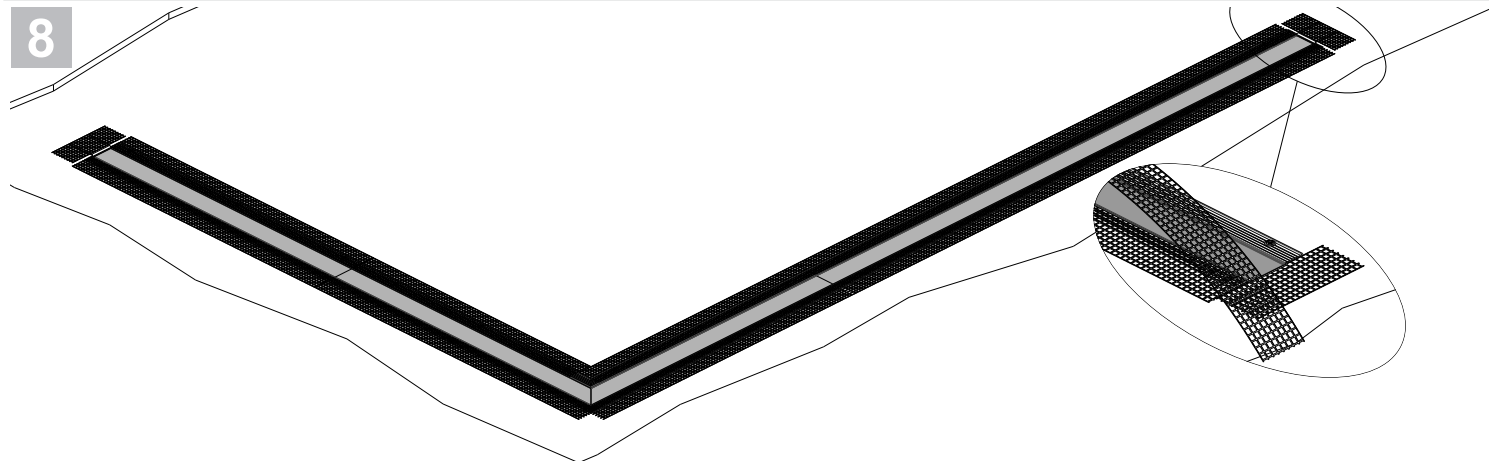

9

Before grouting, mask the internal visible part of the outer casing well

Prima di stuccare mascherare bene la parte interna a vista della cassaforma

Avant le jointoement, bien masquer la partie interne visible du boîtier d'encastrement

Maskieren Sie vor dem Verfugen den sichtbaren inneren Teil der Gehäuse

Antes de aplicar la lechada, enmascarar bien la parte interna visible de la caja de empotrar

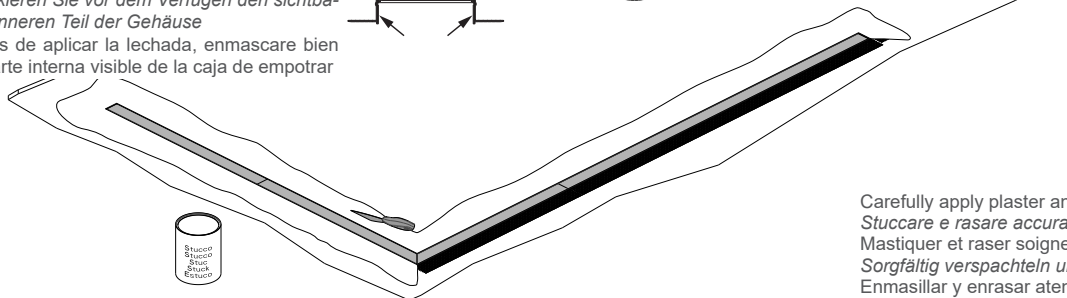
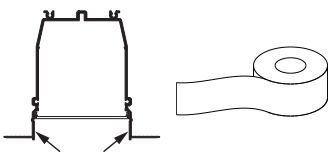

Carefully apply plaster and smooth!
Stuccare e rasare accuratamente!
 Mastiquer et raser soigneusement!
Sorgfältig verspachteln und bündig glattstreichen!
 Enmasillar y enrasar atentamente!

10

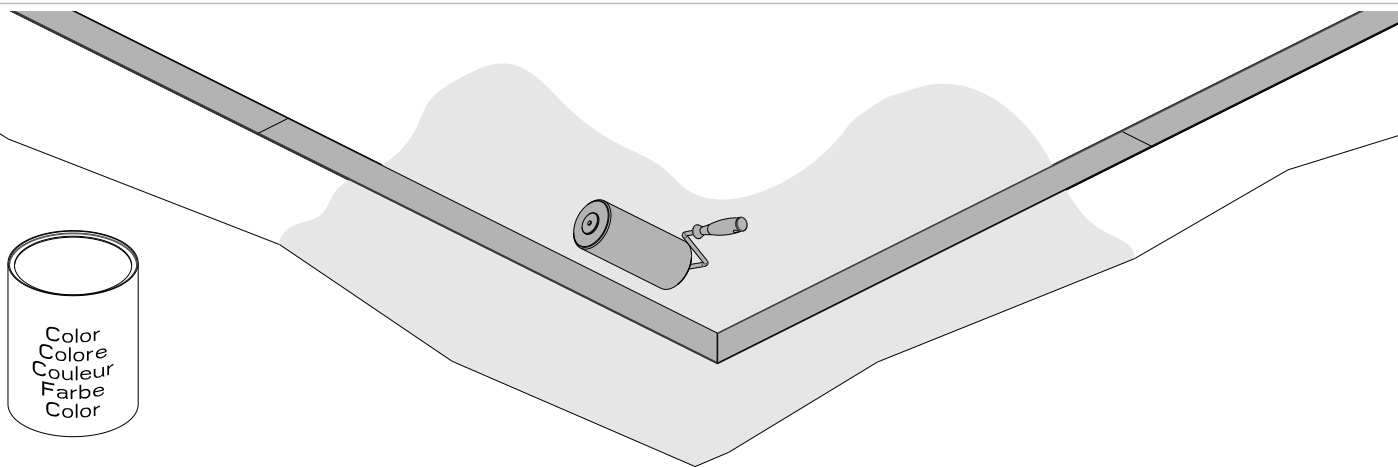

UNION OF MORE OUTER CASINGS
UNIONE DI PIÙ CASSAFORME
UNION DE PLUSIEURS BOÎTIERS D'ENCASTREMENT
UNION VON MEHR GEHÄUSE
UNIÓN DE MÁS CAJAS DE EMPOTRAR

WABR101A

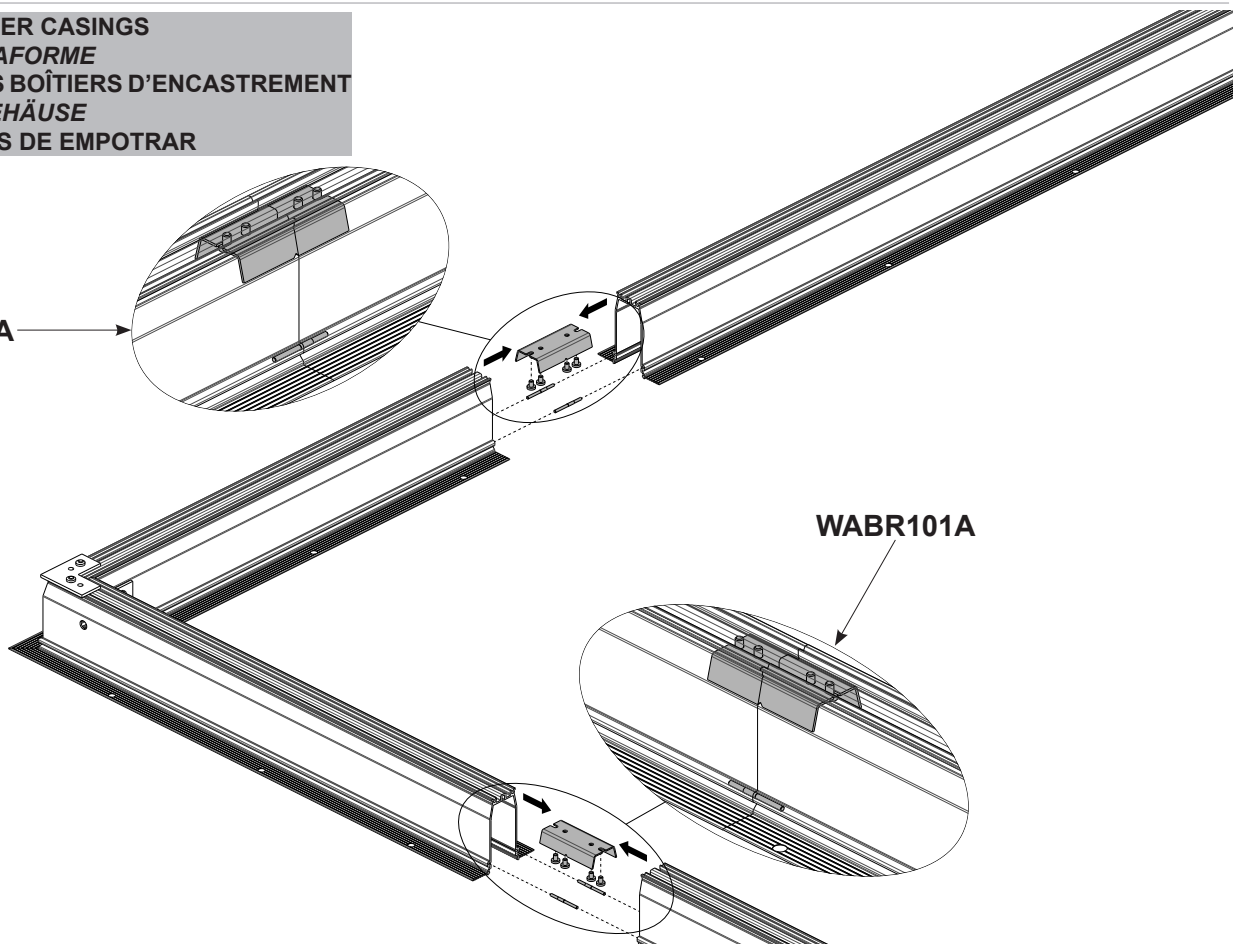

WABR101A